

- SPECIFICATION**
1. Rating : DC 30V 1.0A;
 2. Contact resistance: $\leq 0.05 \Omega$;
 3. Insulation resistance: $\geq 100M \Omega$ (DC250V);
 4. Withstand voltage: 500VAC ;
 5. Insertion and extraction force: 3-20N;
 6. life test: 5,000 cycles.

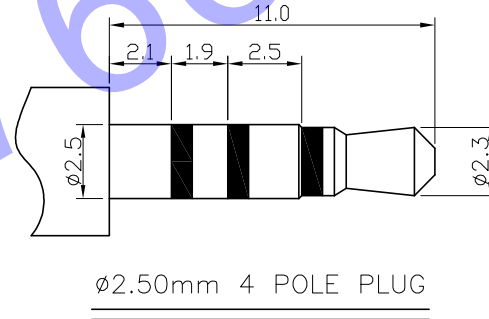

SCHEMATIC

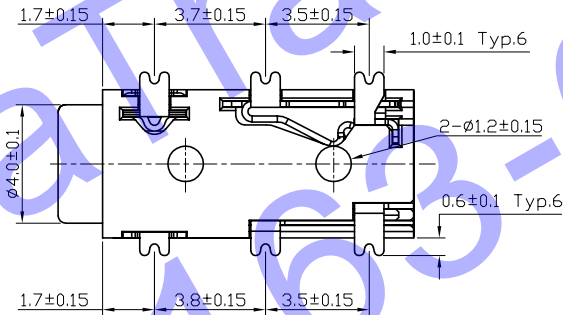
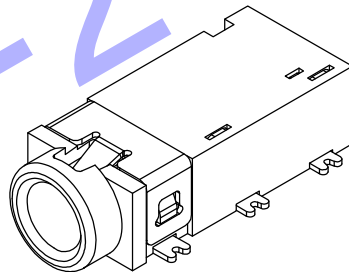
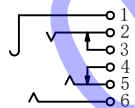

NO.	DESCRIPTION	QTY	MATERIAL	PLATING
7	HOUSING	1	PA9T	
6	6# CONTACT FOOT	1	BRONZE	Au-Plating
5	5# CONTACT FOOT	1	SUS301	Au-Plating
4	4# CONTACT FOOT	1	BRONZE	Au-Plating
3	3# CONTACT FOOT	1	BRONZE	Au-Plating
2	2# CONTACT FOOT	1	SUS301	Au-Plating
1	1# CONTACT FOOT	1	BRONZE	Au-Plating

UNIT:MM	TYPE:	MODEL NO:	PAPER NO: A4	PAGE 1 OF 1	
	PHONE JACK	PJ-S2042X	TOLERANCE	ANGLES	SCALE
			±0.15	±1.5°	4:1
DESIGNER BY:					
CHECK BY:					
APPROVED BY:					

H D C 有限公司